

# NOTTINGHAM

**STRUTTURA** in vero legno rivestita in tessuto protettivo accoppiato con assemblaggio in colla e graffe.

**SOSPENSIONI SEDUTA** con sistema "elast" (cinghie elastiche).

**CUSCINO SEDUTA** cuscino in piuma canalizzata in fodera di cotone con inserto interno in poliuretano espanso densità 35kg/m<sup>3</sup>.

**CUSCINO SCHIENALE** gomma in poliuretano espanso densità 45kg/m<sup>3</sup>.

**RIVESTIMENTO** solo cuscini seduta sfoderabili.

**DI SERIE:** struttura pelle/seduta tessuto.

Disponibile anche tutto in pelle con supplemento da listino.

NON DISPONIBILE con letto.

**STRUCTURE** real wood covered with a protection fabric assembled with glue and staples.

**SEAT SUPPORT** "elast system".

**SEAT CUSHION** polyurethane foam density 35kg/m<sup>3</sup> covered with canalized feather cushion on top.

**BACK CUSHION** polyurethane foam density 45kg/m<sup>3</sup>.

**COVERING** only seat cushion cover removable.

This model has frame in leather and cushions in fabric.

Available with frame and cushions in leather by extra cost.

NON AVAILABLE with bed.

**STRUCTURE** vrais bois avec rembourrage en polyuréthane et assemblage colle et agrafes.

**SUSPENSION ASSISE** sangles élastiques.

**MOUSSE ASSISE** mousse en polyuréthane expansé densité 35 kg/m<sup>3</sup>.

**MOUSSE DOSSIER** coussin en plume canalise avec revêtement en coton et insertion en polyurethane densité 45kg/m<sup>3</sup>.

**RETEMENT** seulement assises déhoussables. Standard carcasse en cuir et coussins en tissu.

Avec supplément il peut être réalisé complètement en cuir.

NON DISPONIBILE en convertible.

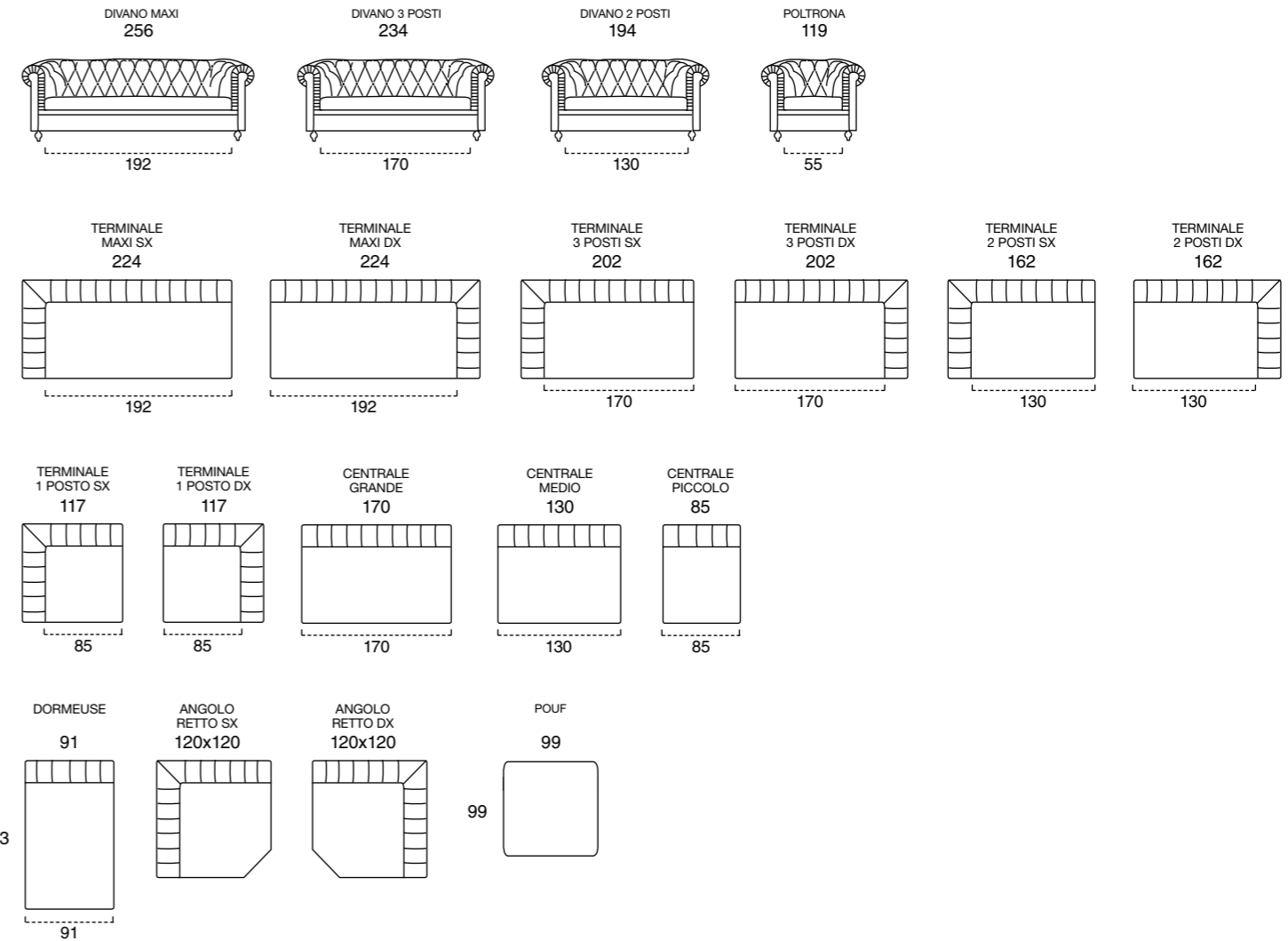

PELLE / LEATHER / CUIR		TESSUTO / FABRIC / TISSU	
STRUTTURA VERO LEGNO REAL WOOD STRUCTURE VRAI BOIS	SPALLIERA IN POLIURETANO ESPANSO BACK WITH POLYURETHANE DOSSIER EN POLYURETHANE	CUSCINO IN PIUMA FEATHER SEAT ASSISE EN PLUME	CUSCINI DI SEDUTA SFODERABILI REMOVABLE UPHOLSTERY FOR SITTING CUSHIONS COUSSINS D'ASSISE DÉHOUSSABLES

## COMPOSIZIONI FOTOGRAFATE / COMPOSITIONS AS IN THE PHOTO / COMPOSITIONS PHOTOGRAPHÉES

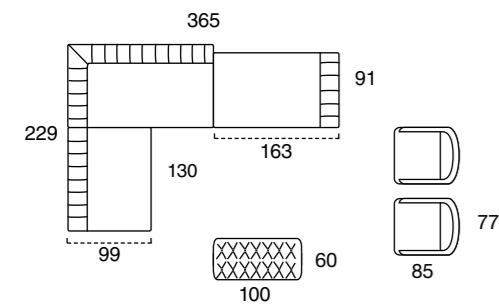

PAGE 114-115

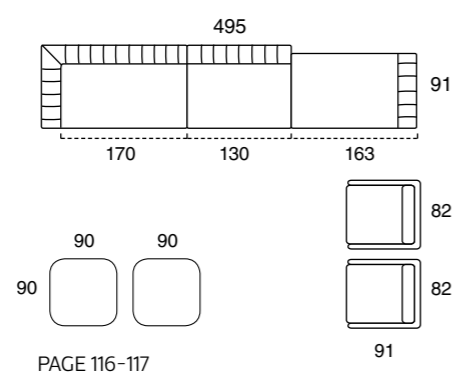

PAGE 116-117

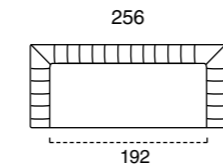

PAGE 120-121

